



# *SD Aluminium* **Farm Fence, Netting Temporay Fence**



**Farm Fence System**



**Safety Mesh**



*May 2024 Edition*

**Temporary Fence**

[www.sdalu.co.nz](http://www.sdalu.co.nz)

# Y-Post / Waratah Systems and Mesh Options









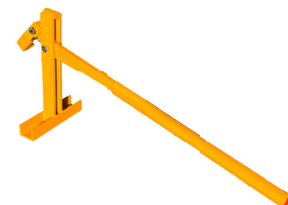

## Galvanized Steel Y Posts - Painted Black

Hot-dip galvanisation for maximum corrosion protection in harsh environments. Primarily used for Temporary Fencing, Gardening and Concrete Boxing applications.



Weight: 1.80kg/m approx.

Product Code	Length	Holes
SYP0.45M	450mm	2
SYP0.6M	600mm	3
SYP0.8M	800mm	5
SYP0.9M	900mm	5
SYP1.2M	1200mm	11
SYP1.35M	1350mm	11
SYP1.5M	1500mm	14
SYP1.65M	1650mm	14
SYP1.8M	1800mm	14
SYP2.4M	2400mm	17
SYP2.7M	2700mm	17
SYP3M	3000mm	17

							
Product Code	SL-45	Product Code	SL-47	Product Code	SL-20	Product Code	SL-21
Description	Post Rammer	Description	Post Lifter	Description	Round Safety Cap	Weight (Kg/m)	Triangle Safety Cap
		 Wire Diametre: 2.0mm Vertical Spacing: 140mm 1.2m(Height) X 50m(Length)		 Wire Diametre: 2.0mm Vertical Spacing: 140mm 1.5m (Height) X 50m (Length)		 Wire Diametre: 2.5mm Diamond Spacing: 50x50mm 0.9m (Height) X 20m (Length)	
Product Code	GM-GYFZ-67	Product Code	FSFH1.2L50	Product Code	FSFH1.5L50	Product Code	CFH0.9L20
Description	Wire Strainer	Description	Sheep Fence Mesh	Description	Sheep Fence Mesh	Description	Chain Link Fence Mesh
 Wire Diametre: 2.5mm Diamond Spacing: 50x50mm 0.9m(Height) X 20m(Length)		 Weight: 100g/m <sup>2</sup> 1m(Height) X 50m(Length)		 Hot Dip Galvanized Net 25 0.9m(Height) X 9m(Length)		 Hot Dip Galvanized Net 13 1m(Height) X 9m(Length)	
Product Code	CFH0.9L20PVC	Product Code	SMW1L50RED	Product Code	SWWFH0.914NS25L9	Product Code	SWWFH1NS13L9
Description	PVC Chain Link Fence Mesh	Description	Orange Safety Mesh	Description	Galvanized Square Wire Mesh	Description	Galvanized Square Wire Mesh

## Temporary Fence Panel

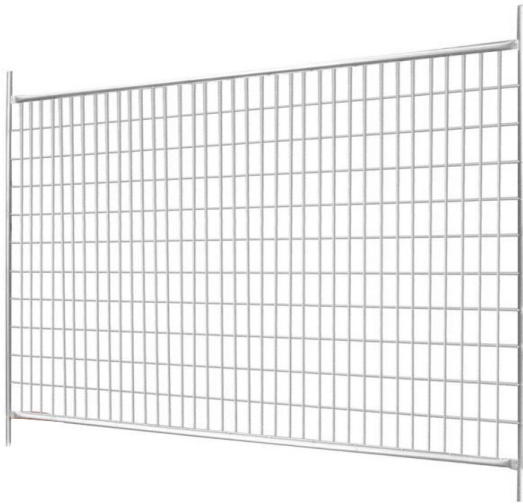

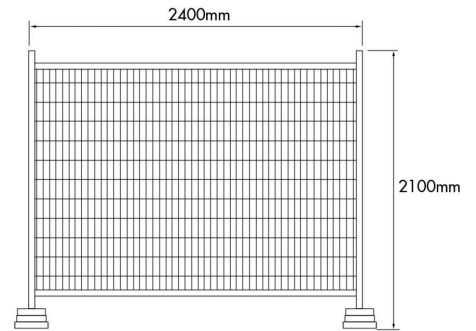

Product Code	Panel Size
TFSH2.1L2.4	2.4m (W) X 2.1m (H)

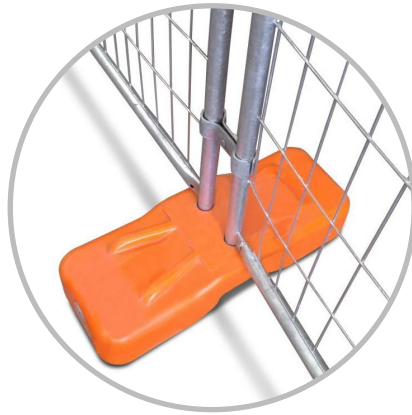

Finish: 14 micron galvanized steel finish  
 Mesh: 150mm X 60mm mesh spacing  
 2.5mm thickness wire mesh



Hot-dip galvanisation for maximum corrosion protection in harsh environments.  
 Primarily used for Civil Construction Projects, Sport Events and Environmental Protection applications.

					
Product Code	SL-71	Product Code	SL-72	Product Code	TFBH2.1L2.4
Description	Concrete Filled Foot	Description	Panel Clamp	Description	Panel Bracing

The logo features the letters 'SD' in a bold, black, sans-serif font. A blue swoosh underline is positioned beneath the 'D'. Below this, the word 'ALUMINIUM' is written in a white, bold, sans-serif font with a black outline. The entire logo is centered against a background of a wire mesh fence and a grassy hill under a clear blue sky.

# SD ALUMINIUM

## Contact Us Now!



### *Auckland Rosedale Branch*

Address: 6 John Glenn Ave, Rosedale, Auckland 0632

Phone: 09-218 2188, 09-218 2111

Email: [info@sdalu.co.nz](mailto:info@sdalu.co.nz)

### *Auckland Manukau Branch*

Address: 28 Ryan Place, Manukau City, Auckland 2104

Phone: 09-217 8666

Email: [info@sdalu.co.nz](mailto:info@sdalu.co.nz)



<https://www.linkedin.com/company/67363257/admin/feed/posts/>



<https://www.linkedin.com/company/67363257/admin/feed/posts/>



<https://www.facebook.com/SDAluminiumLtd>

*Follow Us on Social Media ....*